

## Ground-state entropy and algebraic order at low temperatures

This article has been downloaded from IOPscience. Please scroll down to see the full text article.

1980 J. Phys. A: Math. Gen. 13 L259

(<http://iopscience.iop.org/0305-4470/13/7/008>)

View [the table of contents for this issue](#), or go to the [journal homepage](#) for more

Download details:

IP Address: 129.252.86.83

The article was downloaded on 31/05/2010 at 05:30

Please note that [terms and conditions apply](#).

## LETTER TO THE EDITOR

# Ground-state entropy and algebraic order at low temperatures

A N Berker<sup>†</sup> and Leo P Kadanoff<sup>‡</sup>

<sup>†</sup> Department of Physics, Massachusetts Institute of Technology, Cambridge, Massachusetts 02139, USA

<sup>‡</sup> The James Franck Institute, The University of Chicago, 5640 Ellis Avenue, Chicago, Illinois 60637, USA

Received 13 May 1980

**Abstract.** A rescaling argument is applied to systems with a highly degenerate ground state. It is suggested that these systems can exhibit a distinctive low-temperature phase in which correlations decay algebraically with distance. This behaviour seems to be permitted when the spatial dimensionality is sufficiently high,  $d \geq d_c$ . In addition, we find at  $d_c$  an infinite-order phase transition ( $\nu = \infty$ ,  $\alpha = -\infty$ ) occurring at non-zero temperature, and only paramagnetic behaviour at  $d < d_c$ . Since our results arise from a one-parameter renormalisation-group viewpoint, they should be seen as suggestive rather than definitive.

This Letter describes the application of a simple rescaling argument (Kadanoff 1966) to systems in which the residual (ground-state) entropy is of the order of the number of particles. The distinctive low-temperature phase which is suggested might occur in antiferromagnetic Potts (1952) models and in other systems frustrated (Toulouse 1977) because of heterogeneity or geometry, including perhaps some spin glasses (Edwards and Anderson 1975).

First, for contrast, consider a system in which the ground-state entropy per particle,  $S_0$ , is zero, namely the Ising antiferromagnet

$$-\mathcal{H}/kT = -K \sum_{\langle ij \rangle} \sigma_i \sigma_j \quad K \geq 0 \quad (1)$$

where  $\langle ij \rangle$  denotes summation over nearest-neighbour pairs, and each spin  $\sigma_i = \pm 1$  is at a site  $i$  of a hypercubic lattice in  $d$  dimensions. Part of this lattice is shown in figure 1. At zero temperature,  $K \rightarrow \infty$ , only two antiferromagnetic ground states contribute to the partition function. Either state is characterised by the fact that the spin at site 1 is firmly antiparallel to the spin at the nearest-neighbour site 2,  $\sigma_1 = -\sigma_2$ . Similarly,  $\sigma_2 = -\sigma_3$  and  $\sigma_3 = -\sigma_4$ . Therefore, in the simplest rescaling transformation (Kadanoff and Houghton 1975), if spins  $\sigma_2$  and  $\sigma_3$  are summed over and eliminated from the partition function,  $\sigma_1$  and  $\sigma_4$  become nearest neighbours and  $\sigma_1 = -\sigma_4$ . Thus, the zero-temperature character is preserved. This is why  $T = 0$  is a fixed point, as shown in figure 2(a). This argument also follows from any rescaling transformation appropriate for antiferromagnetic problems, for example, the block transformation introduced by van Leeuwen (1975).

Turning to systems with non-zero ground-state entropy per particle, we illustrate the argument with perhaps the simplest of such systems, the antiferromagnetic Potts

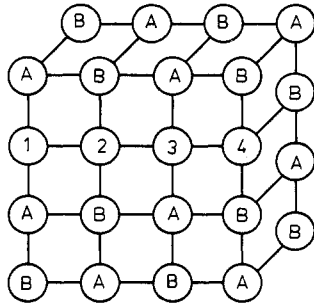

**Figure 1.** In systems with residual entropy, sites 1 and 4 are not firmly aligned at  $T = 0$ . Therefore, the zero-temperature state maps, under a scale change, onto a non-zero effective temperature determined by the ground-state entropy.

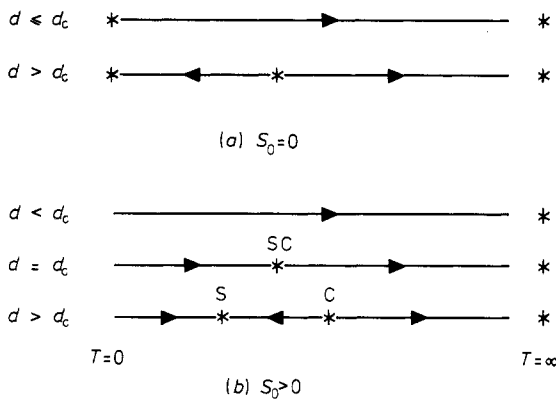

**Figure 2.** Renormalisation-group flows and fixed points (\*) for systems without and with residual entropy per site,  $S_0$ . In the latter case,  $T = 0$  is not a fixed point, as the system renormalises away from it with a finite jump in effective temperature.

models. As the discussion progresses, it will be evident that our argument is more general, requiring only a high degeneracy and a very high degree of complexity of the ground state. The antiferromagnetic Potts models are defined by the Hamiltonian

$$-\mathcal{H}/kT = -J \sum_{\langle ij \rangle} \delta_{s_i s_j} \quad J \geq 0 \tag{2}$$

where  $s_i = a, b, c \dots$  is in one of the  $q$  states, and  $\delta_{s_i s_j} = 1(0)$  when  $s_i = s_j$  ( $s_i \neq s_j$ ). First, we exhibit the ground-state entropy. The hypercubic lattice can be divided into two sublattices, A and B in figure 1, so that any site of either sublattice has as nearest neighbours only sites of the other sublattice. The energy is minimised to zero when, for example, all sites of sublattice A are in state  $a$ , and each site of sublattice B is independently in any one of the  $q - 1$  other states. Accordingly, the ground-state multiplicity  $\omega_0$  is bounded below by  $(q - 1)^{N/2}$ , where  $N$  is the total number of sites. The ground-state entropy per site,  $S_0 = \ln \omega_0 / N$ , is bounded by

$$\frac{1}{2} \ln(q - 1) < S_0 < \ln q, \tag{3}$$

and therefore is non-zero for  $q > 2$ . To see how long-range correlations might arise, consider the minimum energy configuration in which all sites in sublattices A and B are

respectively in states  $a$  and  $b$ . Other minimum energy configurations are generated by changing all A and B sites in any region to new states  $a'$  and  $b'$ , respectively, as long as  $b \neq a' \neq b' \neq a$ . The continuation of this construction leads to arbitrarily complex configurations, with the complexity felt on arbitrarily long length scales. This could be the analogue of critical fluctuations of an ordinary critical point.

We now analyse this situation with a rescaling argument (Kadanoff 1966). At zero temperature,  $J \rightarrow \infty$ , only the (numerous) ground-state configurations contribute equally to the partition function. In each ground-state configuration, no two nearest-neighbour sites are in the same state. For a moment, consider only such configurations of the straight path connecting sites 1 and 4 (figure 1). For given  $s_1$  and  $s_4$ , there are  $q^2 - 3q + 3$  configurations of  $\{s_2, s_3\}$  if  $s_1 \neq s_4$ , and  $q^2 - 3q + 2$  configurations if  $s_1 = s_4$ . Therefore, if spins  $s_2$  and  $s_3$  are summed over and eliminated from the partition function,  $s_1$  and  $s_4$  become nearest neighbours, but the zero-temperature character is lost, since  $s_1 = s_4$  with non-zero multiplicity. This multiplicity is smaller than that of  $s_1 \neq s_4$ , so that the rescaled system is still an antiferromagnet, but not at zero temperature. Including the remainder of the connectivity of the lattice does not qualitatively alter this result, being equivalent to considering other, more convoluted paths as well. The fact is that, due to the microscopic multiplicity of the configurations, the zero-temperature condition is not propagated between distant spins. Any rescaling transformation, which in effect brings together distant spins, should reflect this by yielding, when applied to the zero-temperature system, a renormalised temperature which is non-zero.

Thus it is argued that a single rescaling renormalises zero temperature to a non-zero temperature. This happens in a single discrete jump, the magnitude of which is determined by the ground-state entropy  $S_0$ , so that  $T = 0$  is not even an unstable fixed point. This is shown in figure 2(b). The effect of subsequent, repeated rescalings is important. One possibility is that each rescaling increases the effective temperature, amounting to a renormalisation-group trajectory (Wilson 1971) flowing to the  $T = \infty$  ( $J = 0$ ) fixed point which is always trivially present. This is shown at the top of figure 2(b), and signifies that the system is in the disordered phase at all temperatures.

Another possibility is that the renormalisation-group trajectory originating at  $T = 0$  flows to a stable fixed point  $S^*$  at non-zero, non-infinite temperature. This is shown at the bottom of figure 2(b). It is known that at a fixed point the correlation length  $\xi$  is zero or infinite (Wilson 1971). The former holds in the case, for example, of the trivial fixed point at  $T = \infty$ ; but a fixed point at non-zero, non-infinite temperature is associated with critical behaviour. Therefore, in this interpretation,  $\xi = \infty$  at  $S^*$  and, consequently, throughout the temperature region which renormalises to  $S^*$ . This means that correlations decay algebraically,  $g(r) \sim r^{d-2-\eta}$ , throughout this distinct low-temperature phase, but with a single universal exponent  $\eta$  determined at  $S^*$ . Furthermore, there is no obvious order parameter. The occurrence of  $S^*$  indicates that the complex subset of configurations, the construction of which was given above, remains statistically dominant at every length scale.

The first possibility mentioned above, a disordered phase along the entire temperature range, would be expected at low dimensions, whereas the second possibility, with a distinct low-temperature phase, would be expected at high dimensions. This expectation is based on general experience with phase transitions, which supports the simple *a priori* reasoning that the high connectivity of high dimensions strengthens the correlations. This is seen even for the jump in effective temperature resulting from the rescaling at  $T = 0$  described above. At higher dimensions, more paths join sites 1 and 4,

the configurations of each path, although including  $s_1 = s_4$ , favouring  $s_1 \neq s_4$ . Thus, at higher  $d$ , the renormalised temperature is lower and, this tendency persisting in subsequent rescaling, eventual renormalisation to  $T = \infty$  is less likely. (In fact, a conventional discontinuity fixed point (Nienhuis and Nauenberg 1975) is recovered in the limit  $d \rightarrow \infty$ , with  $S^*$  moving to zero temperature.) Another way of viewing the effect of dimensionality is that the higher connectivity puts constraints on the above construction of minimum energy configurations, restricting their number (still very large,  $O(p^N)$ ,  $p < q$ ) relative to the number  $q^N$  of all possible configurations. Without a certain amount of such restriction, the system under thermal fluctuations becomes trivially degenerate, namely disordered.

The simplest mechanism, for passing from the low- $d$  regime to the high- $d$  regime is the creation of a pair of fixed points at some lower critical dimension  $d_c$  (the middle part of figure 2(b)). The two fixed points are merged at  $d_c$ . They separate at  $d > d_c$ , the lower temperature one being the stable  $S^*$  discussed above, the sink of the low-temperature phase, and the higher temperature one being the unstable  $C^*$ , the fixed point of the phase transition. Accordingly, at  $d_c$ , (i) the temperature of the merged pair is the transition temperature  $T_C(d_c)$ , which is non-zero, (ii) the merged fixed point has a marginal direction, so that the phase transition is infinite order, i.e. with  $\nu = \infty$  and  $\alpha = -\infty$ , (iii) the critical exponents such as  $\eta$  are the same along the entire low-temperature phase and at the phase transition, being all determined at the merged fixed point. By contrast, for  $d > d_c$ , the exponents are different in the low-temperature phase and at the transition point, being respectively determined at  $S^*$  and  $C^*$ . As  $d$  approaches  $d_c$  from below, although there is no actual phase transition, by continuity the renormalisation-group flows should slow down around the temperature  $T_C(d_c)$ . This will cause a large correlation length (and consequently large response functions) to accumulate for temperatures below  $T_C(d_c)$ , as precursor to the behaviour at  $d_c$ .

All of the behaviour deduced above, including  $d \geq d_c$  and  $d = d_c$ , has in fact been obtained for the antiferromagnetic  $q$ -state Potts models and for the completely frustrated Ashkin-Teller (1943) model, using the approximate renormalisation procedure of Migdal (1975) in the variant of Kadanoff (1976). Some results are shown in figure 3, and details will be given elsewhere. In these models, when the residual entropy is removed from the system, the novel behaviour presented here disappears. For the Ashkin-Teller model, a conventional low-temperature phase is entered as soon as the frustration is removed. For the antiferromagnetic Potts models, the residual entropy is removed as  $q \rightarrow 2$  from above (equation (3)). As  $q \rightarrow 2$  in our approximate calculation,  $d_c = 1 - 1/\ln(q-2) \rightarrow 1$  and  $T_C(d_c) = d_c - 1 \rightarrow 0$ .

Thus this algebraically ordered behaviour is supported by an approximate calculation, which, just as the *a priori* rescaling argument above, incorporates a one-parameter renormalisation-group viewpoint. In fact, this behaviour could disappear in a more sophisticated calculation involving additional couplings, if the renormalisation trajectory originating at  $T = 0$  did flow to a limit in which all couplings were infinity. By such a mechanism of losing ground-state entropy under renormalisation, conventionally ordered phases and/or first-order phase transitions could result. Nevertheless, the novel phenomena discussed here remain an open possibility, especially for antiferromagnetic Potts models, which might be sought with either Monte-Carlo or series analysis.

Perhaps, in the end, this suggestion about algebraically decaying correlations caused by residual entropy is not so surprising. This is found in two-dimensional ice models (Lieb and Wu 1972). In these models, the ground-state entropy is realised by a variety

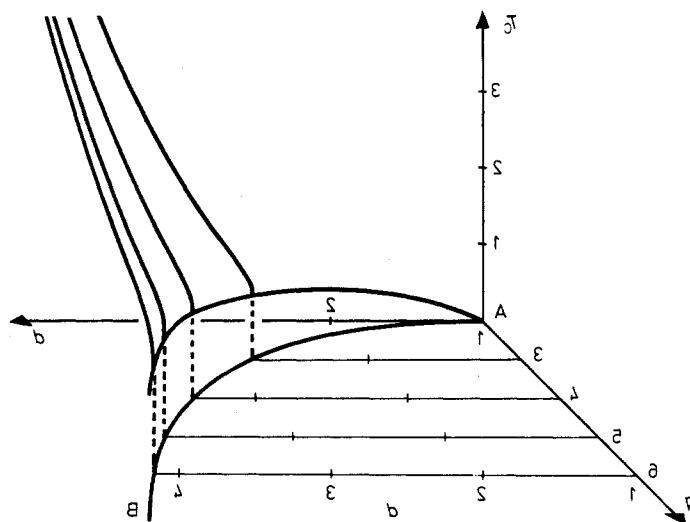

**Figure 3.** Transition temperatures  $T_C$  of a simple system with residual entropy, the antiferromagnetic Potts model, as a function of dimension  $d$  and number of states  $q$ . The curve AB gives the lower critical dimension  $d_c(q)$ , while the curve AE gives the jump discontinuity of  $T_C$  at  $d_c$ . These results were obtained using the approximate Migdal-Kadanoff renormalisation in the infinitesimal rescaling limit.

of symmetry transforms on different configurations. Depending upon the configuration, the transform may permit either independent changes in groups of few neighbouring degrees of freedom, or correlated changes of very many linked degrees of freedom. Thus, ice models (as well as  $d$ -dimensional antiferromagnetic Potts models considered here) can include ground-state configurations whose arbitrary complexity extends over arbitrary length scales, similarly to fluctuations at a critical point. (In contrast, models with gauge symmetries (Wegner 1971) have local symmetry transforms, and cannot show highly degenerate *and* correlated ground-state structure beyond the microscopic scale.)

Further, systems of ( $n \geq 2$ )-component spins have a basic degeneracy left even after a symmetry is broken. Below  $T_C$ , these systems produce algebraically decaying correlations via the remaining degeneracy of the transverse degrees of freedom (Halperin and Hohenberg 1969). However, as  $T \rightarrow 0$  for  $d > 2$ , the longitudinal ordering saturates and the transverse degrees of freedom disappear, resulting in a  $T = 0$  discontinuity fixed point (Nienhuis and Nauenberg 1975). On the other hand, the  $n = 2, d = 2$  (XY) model (Wegner 1967, Kosterlitz and Thouless 1973, Kosterlitz 1974) is much more like the systems discussed above in that there is no longitudinal ordering and the degenerate transverse degrees of freedom persist to  $T = 0$ . In this case also, no  $T = 0$  discontinuity fixed point occurs.

This research was supported by the National Science Foundation Grant No. DMR-79-26405 and by the Materials Research Laboratory of the University of Chicago.

## References

Ashkin J and Teller E 1943 *Phys. Rev.* **64** 178

- Edwards S F and Anderson P W 1975 *J. Phys. F: Metal Phys.* **5** 965  
Halperin B I and Hohenberg P C 1969 *Phys. Rev.* **188** 898  
Kadanoff L P 1966 *Physica* **2** 263  
— 1976 *Ann. Phys., NY* **100** 359  
Kadanoff L P and Houghton A 1975 *Phys. Rev. B* **11** 377  
Kosterlitz J M 1974 *J. Phys. C: Solid St. Phys.* **7** 1046  
Kosterlitz J M and Thouless D J 1973 *J. Phys. C: Solid St. Phys.* **6** 1181  
van Leeuwen J M J 1975 *Phys. Rev. Lett.* **34** 1056  
Lieb E H and Wu F Y 1972 *Phase Transitions and Critical Phenomena* eds C Domb and M S Green (London: Academic) vol 2  
Migdal A A 1975 *Zh. Eksp. Teor. Fiz.* **69** 1457 (transl 1976 *Sov. Phys.-JETP* **42** 743)  
Nienhuis B and Nauenberg M 1975 *Phys. Rev. Lett.* **35** 477  
Potts R B 1952 *Proc. Camb. Phil. Soc.* **48** 106  
Toulouse G 1977 *Commun. Phys.* **2** 115  
Wegner F J 1967 *Z. Phys.* **206** 465  
— 1971 *J. Math. Phys.* **12** 2259  
Wilson K G 1971 *Phys. Rev. B* **4** 3174, 3184